



MODULAR ICE MAKER
MACHINE A GLACE MODULAIRE
EISBEREITER FÜR SEPARATEN VORRATSBEHÄLTER
IJSMACHINE MET LOSSE OPSLAGBUNKER
MAQUINA DE CUBITOS MODULAR
FABBRICATORE MODULARE DI GHIACCIO

INSTRUCTION MANUAL

(original instructions)

NOTICE D'UTILISATION

(instructions traduites)

BEDIENUNGSANLEITUNG

(Übersetzung)

GEBRUIKSAANWIJZING

(vertaalde instructies)

MANUAL DE INSTRUCCIONES

(instrucciones traducidas)

MANUALE D'ISTRUZIONI

(traduzione)

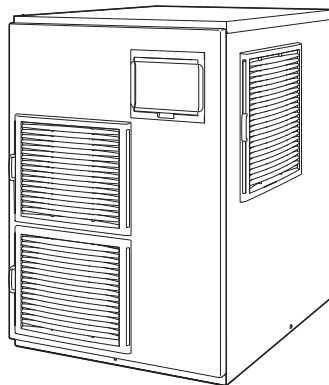

FOR END USER
POUR UTILISATEUR
FÜR DEN ENDKUNDEN
VOOR DE GEBRUIKER
PARA USUARIO
PER L'UTENTE FINALE

FM-150AKE-HC-SB
FM-150AKE-HCN-SB
FM-300AKE-HC
FM-300AKE-HCN
FM-480AKE-HC
FM-480AKE-HCN

HOSHIZAKI EUROPE LIMITED

Telford 70 Stafford Park 7, Telford, Shropshire TF3 3BQ UK

L1F087204 (110521)

ENGLISH	IMPORTANT SAFETY INFORMATION	1
	I. INSTALLATION INSTRUCTIONS.....	3
	1. CONSTRUCTION.....	3
	2. LOCATION.....	3
	3. ELECTRICAL CONNECTIONS.....	3
	4. WATER SUPPLY AND DRAIN CONNECTIONS	4
	II. OPERATING INSTRUCTIONS.....	4
	1. START UP.....	5
	2. SHUT DOWN	5
	3. PREPARING THE ICEMAKER FOR LONG STORAGE.....	5
	III. MAINTENANCE	6
	1. CLEANING	6
	2. INSPECTION AND MAINTENANCE.....	7
	3. BEFORE CALLING FOR SERVICE.....	7
	4. DISPOSAL.....	8
	5. WARRANTY	9
	SPECIFICATIONS.....	10
FRANCAIS	INFORMATIONS DE SECURITE IMPORTANTES	11
	I. CONSIGNES D'INSTALLATION.....	13
	1. CONSTRUCTION.....	13
	2. EMBLACEMENT	13
	3. BRANCHEMENTS ELECTRIQUES.....	14
	4. BRANCHEMENTS D'ARRIVEE ET DE VIDANGE D'EAU.....	14
	II. CONSIGNES D'UTILISATION	15
	1. MISE EN MARCHE	15
	2. ARRET	15
	3. PREPARATION DU DISTRIBUTEUR DE GLACE EN VUE D'UN ENTREPOSAGE DE LONGUE DUREE.....	15
	III. ENTRETIEN.....	16
	1. NETTOYAGE	16
	2. INSPECTION ET ENTRETIEN.....	17
	3. AVANT D'APPELER UN REPARATEUR.....	18
	4. MISE AU REBUT.....	19
	5. GARANTIE	20
	SPECIFICATIONS.....	21
DEUTSCH	WICHTIGE SICHERHEITSHINWEISE	22
	I. INSTALLATIONSANLEITUNG.....	24
	1. KONSTRUKTION	24
	2. AUFSTELLORT	24
	3. ELEKTRISCHE ANSCHLÜSSE	25
	4. WASSERZULAUF- UND WASSERABLAUFANSCHLÜSSE	25
	II. BEDIENUNGSANLEITUNG.....	26
	1. INBETRIEBNAHME.....	26
	2. AUSSCHALTEN.....	26
	3. MASSNAHMEN FÜR DIE LANGFRISTIGE LAGERUNG DES EISSPENDERS.....	26
	III. WARTUNG.....	27
	1. REINIGUNG	27
	2. INSPEKTION UND WARTUNG	28
	3. VOR ANRUF DES KUNDENDIENSTES.....	29
	4. ENTSORGUNG.....	30
	5. GEWÄHRLEISTUNG	31
	TECHNISCHE DATEN	32

IMPORTANT SAFETY INFORMATION

Throughout this manual, notices appear to bring your attention to situations which could result in death, serious injury, or damage to the unit.

▲WARNING	Indicates a hazardous situation which, if not avoided, could result in death or serious injury.
▲CAUTION	Indicates a hazardous situation which, if not avoided, could result in minor or moderate injury.
NOTICE	Indicates a hazardous situation which, if not avoided, could result in damage to the unit.
▲HYGIENE	Indicates important precautions for hygiene and food safety.
IMPORTANT	Indicates important information about the use and care of the unit.

This icemaker uses HFC-free refrigerant (propane) and HFC-free foam insulation that are non-ozone-depleting and environmentally sustainable materials having very low global warming potential.

▲WARNING	
This icemaker contains flammable refrigerant in its cooling unit; installation, handling, servicing and disposal must therefore only be carried out by authorized technicians.	
The refrigerant contained in this icemaker is flammable and sealed in the refrigeration system. Although the refrigerant does not leak out under normal usage, take utmost care when handling this icemaker so as not to cause any damages to the system.	
In the case of accidental damage to the refrigeration system causing refrigerant leak:	
<ul style="list-style-type: none"> * Do not create a source of ignition in the area. * Do not operate electrical switches or plugs in the area. * Do not use naked flame. * Immediately ventilate the area by opening doors and/or windows. * Call service engineer. 	

IMPORTANT	
This booklet is an integral and essential part of the product and should be kept and preserved by the user.	
Please read carefully the guidelines and warnings contained herein as they are intended to provide the user with essential information for the continued safe use and maintenance of the product. In addition, it provides GUIDANCE ONLY to the user on the correct services and site location of the icemaker.	
Please preserve this booklet for any further consultation that may be necessary.	

▲WARNING

This is a commercial icemaker, and should be destined only to be used for the purpose for which it has been expressly designed and attached to a suitable storage bin as specified by Hoshizaki.

Any other use should be considered improper and therefore dangerous. The manufacturer will not be held liable or responsible for any damage caused by improper, incorrect and unreasonable use.

The installation, and relocation if necessary, must be carried out by qualified personnel, in accordance with current regulations, according to the manufacturer's instructions.

Keep ventilation openings, in the appliance enclosure or in the built-in structure, clear of obstruction.

Do not use mechanical devices or other means to accelerate the defrosting process, other than those recommended by the manufacturer.

The use of any electrical appliance involves the observance of some fundamental rules. In particular:

- * Instances of high humidity and moisture increase the risk of electrical short circuits and potential electrical shocks. If in doubt, disconnect the icemaker.
- * Do not damage the power cord or pull it in order to disconnect the icemaker from the electrical supply network.
- * If the supply cord is damaged, it must be replaced by a replacement cord available from Hoshizaki Parts/Service Centres.
- * Do not touch the electrical parts or operate the switches with damp hands.
- * This appliance is not intended for use by persons (including children) with reduced physical, sensory or mental capabilities, or lack of experience and knowledge, it can however be used by children aged from 8 years and above and persons with reduced physical, sensory or mental capabilities, or lack of experience and knowledge providing they have been given supervision or instruction concerning use of the appliance by a person responsible for their safety.
- * Children shall not play with the appliance.
- * Cleaning and user maintenance shall not be made by children without supervision.
- * Do not attempt to modify the icemaker. Only qualified personnel may disassemble or repair the appliance.

I. INSTALLATION INSTRUCTIONS

1. CONSTRUCTION

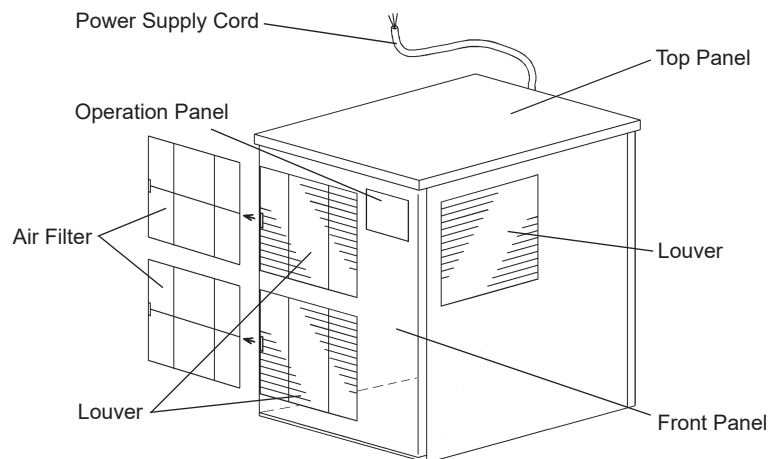

2. LOCATION

⚠ WARNING

This icemaker is not intended for outdoor use.

The icemaker should not be located next to ovens, grills or other high heat producing equipment.

This appliance is not suitable for installation in an area where a water jet could be used.

⚠ CAUTION

The location should provide a firm and level foundation for the icemaker.

NOTICE

Do not place anything on top of the icemaker or in front of the louver.

IMPORTANT

Normal operating ambient temperature should be within 5°C to 40°C. Water connection is cold water only. Operation of the icemaker, for extended periods, outside of these normal temperature ranges may affect production capacity.

Allow the clearance specified below for proper air circulation and ease of maintenance and/or service should they be required.

Top View

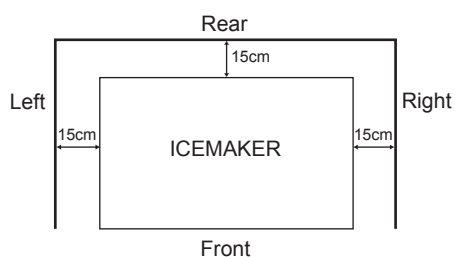

Side View

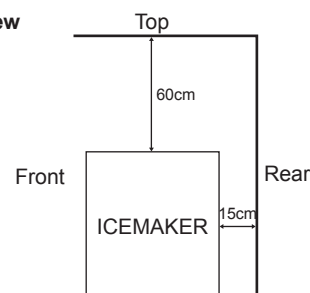

In some high humidity environments, condensation may form inside the machine and drip onto the floor. Do not install where the floor can be affected by water.

Avoid prolonged exposure of the appliance to direct sunlight.

3. ELECTRICAL CONNECTIONS

⚠ WARNING

THIS APPLIANCE MUST BE EARTHED

This icemaker requires an earth that meets the national and local electrical code requirements.

Disconnect the main power supply before any maintenance, repairs or cleaning is undertaken.

ENGLISH

* Usually an electrical permit and services of a licensed electrician are required.

For the U.K. and the Republic of Ireland only

- * The wires in the mains lead are coloured in accordance with the following code:
 - Green & Yellow = Earth
 - Blue = Neutral
 - Brown = Live

As the colours of the wire in the mains lead of this appliance may not correspond with the coloured markings identifying the terminals in your plug, proceed as follows:

The wire which is coloured Green-and-Yellow must be connected to the terminal in the plug which is marked with the letter E or by the symbol \perp or coloured Green or Green-and-Yellow. The wire which is coloured Blue must be connected to the terminal which is marked with the letter N or coloured Black. The wire which is coloured Brown must be connected to the terminal which is marked with the letter L or coloured Red.

- * Should the socket outlets in the installation site not be suitable for the plug supplied with your product, the plug must be removed (cut off if it is moulded on plug) and an appropriate plug fitted.

If the non-rewirable plug has been cut from the power supply cord, it must be disposed of. There should be no attempt to reuse it. Inserting such a plug into a socket elsewhere presents a serious risk of electrical shock.

- * The non-rewirable plug must never be used without a fuse cover being fitted.

The correct replacement for the detachable fuse cover is identifiable from the manufacturer's reference number stamped on the plug.

Supply of replacement fuse covers can be obtained from Hoshizaki Parts/Service Centres.

Fuses should be rated at 10A (FM-150, 300) / 13A (FM-480) and approved to BS 1362.

4. WATER SUPPLY AND DRAIN CONNECTIONS

⚠ WARNING

Connect to potable cold water supply only.

- * The connections to the mains water supply must be made in accordance with the countries' current requirements of the Water Supply or Water Fittings Regulations.
- * Icemaking water must be potable water. Where scaling can be caused by water quality, installation of an external filter or softener is recommended. Contact your local water treatment professional or Hoshizaki service agent.
- * A plumbing permit and services of a licensed plumber may be required in some areas.

II. OPERATING INSTRUCTIONS

⚠ CAUTION

Do not step into the storage bin, or put your hands into the machine compartment inside the storage bin. Children can get trapped inside, or the icemaking mechanism may suddenly move, resulting in injury.

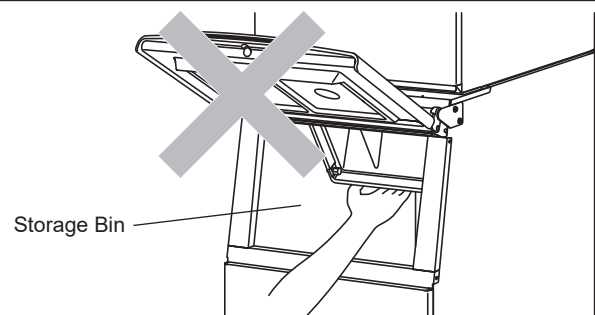

NOTICE

All parts are factory-adjusted. Improper adjustments may result in failure.

If the unit is turned off, wait for at least 3 minutes before restarting the icemaker to prevent damage to the compressor.

HYGIENE

This icemaker is designed to produce edible ice. To keep the icemaker hygienic:

- * Wash your hands before removing ice. Use the plastic scoop provided (accessory).
- * The storage bin is for ice use only. Do not store anything else in the bin nor use other electrical appliances in the bin.
- * Clean the storage bin before use (see "III. 1. CLEANING").
- * Keep the scoop clean. Clean it by using a neutral cleaner and rinse thoroughly.
- * Close the door after removing ice to prevent entrance of dirt, dust or insects into the storage bin.

1. START UP

The installer will normally commission the icemaker to start the automatic icemaking process. To ensure continuous operation, make sure that:

- * The water supply tap is on, and
- * The icemaker is connected to the power supply.

To start the icemaking process, check the position of the operation switch on the operation panel:

- "OFF" position - Move it to the "ON" position.
- "ON" position - Press the ice button.

2. SHUT DOWN

Press the stop button on the operation panel. The "STOP" and "DRAIN" modes light up on the display. Then, only the "DRAIN" mode goes off.

3. PREPARING THE ICEMAKER FOR LONG STORAGE

NOTICE

This icemaker will not work at subfreezing temperatures. To prevent damage to the water supply line, drain the icemaker when air temperature is below zero.

HYGIENE

When shutting down the icemaker for two or more days, drain the icemaker to prevent contamination in the water circuit.

- 1) Follow the instructions in "2. SHUT DOWN".
- 2) Close the water supply line shut-off valve.
- 3) Open the drain valve.
- 4) Press the ice button on the operation panel to drain the water circuit.
- 5) When no more water comes out of the drain valve, press the stop button.
- 6) Move the operation switch to the "OFF" position, and disconnect the power supply.
- 7) Close the drain valve.
- 8) Remove all ice from the storage bin, and clean the bin.

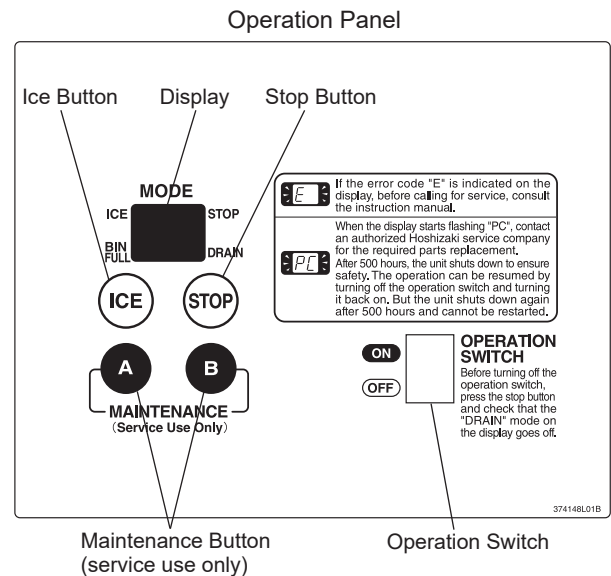

III. MAINTENANCE

1. CLEANING

⚠ WARNING

Before carrying out any cleaning or maintenance operations, unplug the icemaker from the electrical supply network.

This appliance must not be cleaned by use of a water jet.

⚠ CAUTION

When using a neutral cleaner or sodium hypochlorite, thoroughly read and understand the instructions provided to prevent potential health problems.

NOTICE

Ask a trained service person to clean and sanitise the icemaker water system at least twice a year and to check and clean the condenser at least once a year.

To prevent possible damage, do not clean the plastic parts with water above 40°C or in a dishwasher.

[a] Machine and Bin Exterior

Wipe the exterior at least once per week with a clean, soft cloth. Use a damp cloth containing a neutral cleaner to wipe off grease or dirt.

[b] Scoop and Storage Bin Handle Cleaning/Sanitisation (Daily)

1) Either mix 1 litre of water with 4 ml of 5.25% sodium hypochlorite solution in a suitable container, or the recommended Hoshizaki sanitiser as directed.

2) Soak the scoop in the solution for more than 3 minutes. Rinse thoroughly, and shake to remove surplus liquid.

Note: Using a cloth to dry may re-contaminate.

3) Use a neutral cleaner to wash the storage bin handle. Rinse thoroughly.

4) Soak a clean cloth with the sanitising solution, and wipe the handle. Use fresh water and a clean cloth to rinse/dry.

[c] Storage Bin Interior Cleaning/Sanitisation (Weekly)

1) Open the storage bin door, and remove all ice.

Note: Hoshizaki recommends various types of storage bin for the icemaker which vary in size and design. The following instructions are therefore for general guidance only.

2) Remove the thumbscrews securing the baffle.

3) Remove the baffle from the bin.

4) Wash the bin liner, and baffle with a neutral non-abrasive cleaner. Rinse thoroughly.

5) Either mix 5 litres of water with 18 ml of 5.25% sodium hypochlorite solution in a suitable container, or the recommended Hoshizaki sanitiser as directed.

6) Soak a clean sponge or cloth with the solution, and wipe the bin liner surfaces, and baffle.

7) Refit the baffle and thumbscrews. Wipe the surface of the bin door and thumbscrews with the solution. Close the bin door.

8) The remaining solution can be used to sanitise utensils.

Note: Do not wipe dry or rinse after sanitising, but allow to air dry.

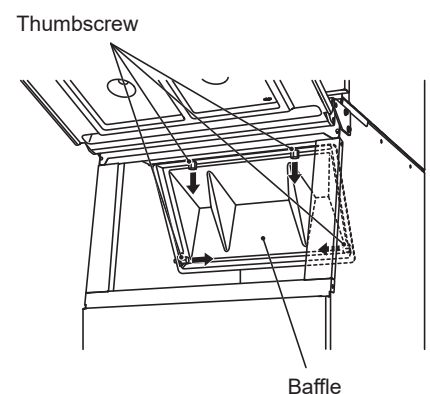

[d] Storage Bin Door

Clean the storage bin door at least once a week, using a neutral non-abrasive cleaner. Rinse thoroughly after cleaning and sanitise as required.

[e] Air Filter

Plastic mesh air filters remove dirt or dust from the air, and keep the condenser from getting clogged. If the filters get clogged, the icemaker's performance will be reduced. Remove and clean the air filter(s) at least twice per month:

- 1) Slide the air filter off the louver.
- 2) Clean the air filter by using a vacuum cleaner. When severely clogged, use warm water and a neutral cleaner to wash the air filter.
- 3) Rinse and dry the air filter thoroughly.

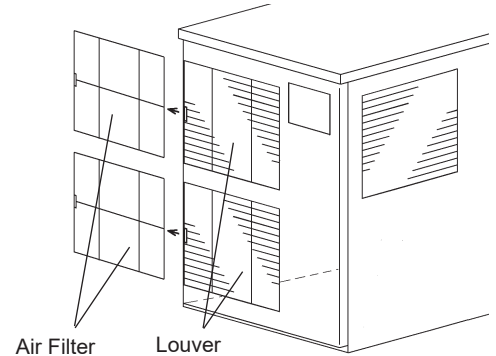

NOTICE

After cleaning, be sure to place the air filter back in position.

2. INSPECTION AND MAINTENANCE

NOTICE

To achieve optimum icemaker performance, the following parts need periodic inspection and maintenance:

- Extruding head (upper bearing)
- Housing (lower bearing)
- Mechanical seal

[a] Inspection

These parts should be inspected after two years from installation or 10,000 hours of operation, whichever comes first, and once a year afterwards. Replacement of these parts is required if wear exceeds factory recommendations.

Their service life, however, depends on water quality and environment. More frequent inspection and maintenance are recommended in bad or severe water conditions.

Consult with your local Hoshizaki service agent about inspection and maintenance service.

[b] Replacement

The extruding head (upper bearing) and mechanical seal must be replaced after four years from installation or 20,000 hours of operation, whichever comes first, to prevent the risk of serious accidents or failures. Contact your local Hoshizaki service agent for replacement.

When the total operating time reaches 20,000 hours, the display flashes "PC". Then, after 500 hours, the unit shuts down to ensure safety. Contact your local Hoshizaki service agent for replacement as soon as the display starts flashing.

Once the unit shuts down after 500 hours, the operation can be resumed by turning off the operation switch and turning it back on. But the unit shuts down again after 500 hours. To resume the operation, contact your local Hoshizaki service agent for the required replacement.

Replacement of the housing (lower bearing) may be required depending on water quality and wear condition.

3. BEFORE CALLING FOR SERVICE

⚠ WARNING

Do not damage the refrigerant circuit. In the case of accidental damage to the refrigeration system causing refrigerant leak:

- * Do not create a source of ignition in the area.
- * Do not operate electrical switches or plugs in the area.
- * Do not use naked flame.
- * Immediately ventilate the area by opening doors and/or windows.
- * Call service engineer.

ENGLISH

[a] Error Code Indication

If the error code "E" is indicated on the display, before calling for service, check the following.

Code	Remedy
E0	Possibility of water leaks. Turn OFF operation switch, and turn it ON again. If error code appears again, call for service.
E1	Low ice production. Turn OFF operation switch, and turn it ON again. If error code appears again, call for service.
E2	Water supply circuit failure. Turn OFF operation switch, and turn it ON again. If error code appears again, call for service.
E3	Gear motor failure. Turn OFF operation switch, and turn it ON again after 10 minutes. If error code appears again, call for service.
E4	Abnormal high side pressure. Clean air filter. Check that icemaker is properly installed according to installation manual. Turn OFF operation switch, and turn it ON again. If error code appears again, call for service.
E5	Electric circuit failure. Turn OFF operation switch, and turn it ON again. If error code appears again, call for service.
E8	Compressor could be overheated. Check that icemaker is properly installed according to installation manual. Turn OFF operation switch, and turn it ON again after 10 minutes. If error code appears again, call for service.
EA	Electric circuit failure. Turn OFF operation switch, and turn it ON again. If error code appears again, call for service.
Eb	Electric circuit failure. Turn OFF operation switch, and turn it ON again. If error code appears again, call for service.
EC	Electric circuit failure. Turn OFF operation switch, and turn it ON again. If error code appears again, call for service.
EE	Gear motor failure. Turn OFF operation switch, and turn it ON again. If error code appears again, call for service.
EF	Supply voltage is too low. Check that voltage is in required range and icemaker is not sharing a single receptacle with other appliances. Turn OFF operation switch, and turn it ON again. If error code appears again, call for service.
EH	Electric circuit failure. Turn OFF operation switch, and turn it ON again. If error code appears again, call for service.
EL	Bin control switch has failed. Turn OFF operation switch, and turn it ON again. If error code appears again, call for service.
En	Electric circuit failure. Turn OFF operation switch, and turn it ON again. If error code appears again, call for service.
EU	Controller board failure. Turn OFF operation switch, and turn it ON again. If error code appears again, call for service.

[b] No Error Code Indication

If the icemaker does not work properly or does not work at all and no error code is indicated on the display, before calling for service, check that:

- * The power is supplied to the unit.
- * The water is turned on.
- * The air filter is clean.

For further assistance or advice, contact your local Hoshizaki service agent.

4. DISPOSAL

Comply with local regulations regarding disposal of this appliance and its refrigerant gas. Before you scrap the appliance, take off the door to prevent children trapped.

Correct disposal of this product:

This marking indicates that this product should not be disposed with other household wastes throughout the EU. To prevent possible harm to the environment or human health from uncontrolled waste disposal, recycle it responsibly to promote the sustainable reuse of material resources. To return your used device, use the return and collection systems or contact the retailer where the product was purchased. They can take this product for environmental safe recycling.



5. WARRANTY

Hoshizaki warrants to the original owner/user that all Hoshizaki branded products shall be free of defects in material and/or workmanship for the duration of the "warranty period". The warranty shall be effective for two years from the date of installation. Hoshizaki's liability under the terms of the warranty are limited and shall exclude routine servicing, cleaning, essential maintenance and/or repairs occasioned by misuse and installations not in accordance with Hoshizaki guidelines.

Warranty repairs should be completed by an approved Hoshizaki dealer or service agency using genuine Hoshizaki components.

To obtain full details of your warranty and approved service agency, please contact your dealer/supplier, or the nearest Hoshizaki Service office:

Europe, Middle East, Africa

Hoshizaki UK - UK, Ireland
TEL: +44 845 456 0585
FAX: +44 132 283 8331
uksales@hoshizaki.uk

Hoshizaki Middle East - Middle East
TEL: +971 48 876 612
FAX: +971 48 876 613
sales@hoshizaki.ae

Hoshizaki Deutschland - Germany, Switzerland, Austria,
Poland, Czech Republic, Slovakia
TEL: +49 5121 697370
FAX: +49 5121 6973719
vertrieb@hoshizaki.de

Hoshizaki Benelux - Netherlands, Belgium, Luxembourg
TEL: +31 85 018 83 70
info@hoshizaki.nl

Hoshizaki France - France
TEL: +33 1 48 63 93 80
FAX: +33 1 48 63 93 88
info@hoshizaki.fr

Hoshizaki Italia - Italy
TEL: +39 344 0616467
TEL: +39 348 3022156
info@hoshizaki.it

Hoshizaki Iberia - Spain, Portugal
TEL: +34 93 478 09 52
FAX: +34 93 478 08 00
info@hoshizaki.es

Hoshizaki Europe B.V. - all other countries within Europe and
Africa
TEL: +31 20 6918499
FAX: +31 20 6918768
sales@hoshizaki.nl

Asia, Oceania

Hoshizaki Singapore
TEL: +65 6225 2612
FAX: +65 6225 3219
sales@hoshizaki.com.sg (Sales)
serviceadmin@hoshizaki.com.sg (Technical support)

Hoshizaki Hong Kong
TEL: +852 2866 2108
FAX: +852 2866 2109

Hoshizaki Taiwan
TEL: +886 2 2706 8818
FAX: +886 2 2708 7999

Hoshizaki Lancer
TEL: +61 8 8268 1388
FAX: +61 8 8268 1978

ENGLISH

SPECIFICATIONS

Model	FM-150AKE-HC-SB	FM-150AKE-HCN-SB
Type	Air-cooled, flake ice	Air-cooled, nugget ice
Power Supply	1 phase 220-240V 50Hz	1 phase 220-240V 50Hz
Electric Consumption	405W	405W
Ice Production per 24h	150kg (ambient 10°C, water 10°C)	140kg (ambient 10°C, water 10°C)
Dimensions	560mm(W) x 720mm(D) x 760mm(H)	560mm(W) x 720mm(D) x 760mm(H)
Refrigerant	R290, 110g	R290, 110g
Insulation Foam Blowing Agent	HFC-free	HFC-free
Weight	Net: 63kg (Gross: 70kg)	Net: 63kg (Gross: 70kg)
Ambient Temp	5 - 40°C	5 - 40°C
Water Supply Temp	5 - 35°C	5 - 35°C
Water Supply Pressure	0.05 - 0.8 MPa (0.5 - 8 bar)	0.05 - 0.8 MPa (0.5 - 8 bar)
Voltage Range	Rated voltage \pm 6%	Rated voltage \pm 6%

Model	FM-300AKE-HC	FM-300AKE-HCN
Type	Air-cooled, flake ice	Air-cooled, nugget ice
Power Supply	1 phase 220-240V 50Hz	1 phase 220-240V 50Hz
Electric Consumption	900W	960W
Ice Production per 24h	300kg (ambient 10°C, water 10°C)	250kg (ambient 10°C, water 10°C)
Dimensions	560mm(W) x 720mm(D) x 780mm(H)	560mm(W) x 720mm(D) x 780mm(H)
Refrigerant	R290, 90g	R290, 90g
Insulation Foam Blowing Agent	HFC-free	HFC-free
Weight	Net: 81kg (Gross: 88kg)	Net: 81kg (Gross: 88kg)
Ambient Temp	5 - 40°C	5 - 40°C
Water Supply Temp	5 - 35°C	5 - 35°C
Water Supply Pressure	0.05 - 0.8 MPa (0.5 - 8 bar)	0.05 - 0.8 MPa (0.5 - 8 bar)
Voltage Range	Rated voltage \pm 6%	Rated voltage \pm 6%

Model	FM-480AKE-HC	FM-480AKE-HCN
Type	Air-cooled, flake ice	Air-cooled, nugget ice
Power Supply	1 phase 220-240V 50Hz	1 phase 220-240V 50Hz
Electric Consumption	1100W	1170W
Ice Production per 24h	450kg (ambient 10°C, water 10°C)	380kg (ambient 10°C, water 10°C)
Dimensions	560mm(W) x 720mm(D) x 780mm(H)	560mm(W) x 720mm(D) x 780mm(H)
Refrigerant	R290, 145g	R290, 145g
Insulation Foam Blowing Agent	HFC-free	HFC-free
Weight	Net: 92kg (Gross: 99kg)	Net: 92kg (Gross: 99kg)
Ambient Temp	5 - 40°C	5 - 40°C
Water Supply Temp	5 - 35°C	5 - 35°C
Water Supply Pressure	0.05 - 0.8 MPa (0.5 - 8 bar)	0.05 - 0.8 MPa (0.5 - 8 bar)
Voltage Range	Rated voltage \pm 6%	Rated voltage \pm 6%

INFORMATIONS DE SECURITE IMPORTANTES

Tout au long de ce manuel, des avis attirent votre attention sur des situations qui pourraient entraîner la mort, des blessures graves ou des dégâts à l'appareil.

▲AVERTISSEMENT	Signale une situation dangereuse qui, si elle n'est pas évitée, peut entraîner des blessures graves voire mortelles.
▲ATTENTION	Signale une situation dangereuse qui, si elle n'est pas évitée, peut entraîner des blessures mineures ou modérées.
AVIS	Signale une situation dangereuse qui, si elle n'est pas évitée, peut entraîner des dégâts à l'appareil.
▲HYGIENE	Signale des précautions importantes à prendre en matière d'hygiène et de sécurité alimentaire.
IMPORTANT	Signale des informations importantes sur l'utilisation de l'appareil et son entretien.

La machine à glace emploie du fluide frigorigène exempt de HFC (propane) et une isolation en mousse exempte de HFC, non nocifs pour la couche d'ozone, ainsi que des matériaux durables qui ont très peu d'impact sur le réchauffement mondial.

▲AVERTISSEMENT
L'unité de refroidissement de cette machine à glace contenant des fluides frigorigènes inflammables, son installation, sa manipulation, son entretien et sa mise au rebut ne doivent être réalisés que par des techniciens agréés.
Le fluide frigorigène de cette machine à glace est inflammable et est enfermé dans le système de réfrigération. Bien que le fluide frigorigène ne présente aucun risque de fuite dans des conditions d'utilisation normales, manipulez la machine à glace avec la plus grande précaution afin d'éviter d'endommager le système.
En cas de fuite de fluide frigorigène résultant d'un dommage accidentel au système de réfrigération : <ul style="list-style-type: none"> * Interdire toute étincelle ou corps incandescent dans le voisinage. * N'utiliser aucun interrupteur ni prise électrique dans le voisinage. * Ne pas utiliser de flamme nue. * Ventiler immédiatement la pièce en ouvrant les portes et/ou fenêtres. * Appeler un technicien de réparation.

IMPORTANT
Ce livret est un élément essentiel qui fait partie intégrante du produit et il doit être conservé soigneusement par l'utilisateur.
Veillez lire attentivement les conseils et avertissements qu'il contient car ils ont pour but de fournir à l'utilisateur des informations essentielles pour la bonne utilisation et l'entretien correct du produit. En outre, il fournit à l'utilisateur des INDICATIONS sur les utilisations et les emplacements corrects de la machine à glace.
Veillez conserver précieusement ce livret pour toute référence ultérieure.