

Client _____ Quantity _____
Project _____ Position _____

Pizza EN60x40 counter 2 doors

Model: TZ13/1M-710

Cod: T40203000261



Technical data

| | |
|---------------------------------|---------------------------------|
| Top: | With top and splashback |
| Gross capacity: | 389 lt |
| Temperature range: | -2°+8°C |
| Refrigerant unit: | Plug-In |
| Energetic class: | B |
| Energy efficiency index: | 32,1 |
| Annual consumption: | 803 kW/h annum |
| 24h consumption: | 2,2 kW/h/24h |
| Climate class: | 5 |
| Cooling gas: | R290 |
| Defrost: | Hot gas |
| Body height: | 710 mm |
| Valve: | Supplied standard with solenoid |
| Dimensions: | 1450×800×1040 mm |
| Packing dimensions: | 1545×900×1080 mm |
| Gross weight: | 220 Kg |
| Voltage: | 220-240 V - 50 Hz |
| Total rate: | 250 W |
| Absorbed Current: | 1,15 A |
| Cooling capacity: | 406 W* |
| *: | Evap. -10°C Cond. +55°C |

Features

| | |
|-------------------------------------|--|
| Standard equipment: | 8 slides EN60x40 |
| Control: | Electronic, display flush with the panel |
| Doors: | 2 doors, self-closing, reversible with 105° stop |
| Door gasket: | Magnetic, triple chamber and easily replaceable |
| Insulation: | 60 mm thickness - CFC/HCFC free |
| Exterior/interior finishing: | Exterior and interior AISI 304 stainless steel. |
| Inner corners: | Rounded for easy cleaning and ensuring maximum hygiene |
| Handle: | Stainless steel AISI 304, 2 mm thick |
| Racks and slides: | Acciaio inox AISI 304 |
| Feets: | Stainless steel AISI 304, adjustable h 100-150 mm |

COSMO - wi-fi control

Cosmo is the innovative wi-fi technology that allows to connect all Coldline appliances in the kitchen and monitor them constantly from your smartphone. Connect Pizza counters to a Cosmo hub (MODI, VISION or LEVTRONIC) and from the app you can check the operating conditions of each machine in real time and receive any alerts in the event of power cuts or improper personnel interventions.



Technical draw

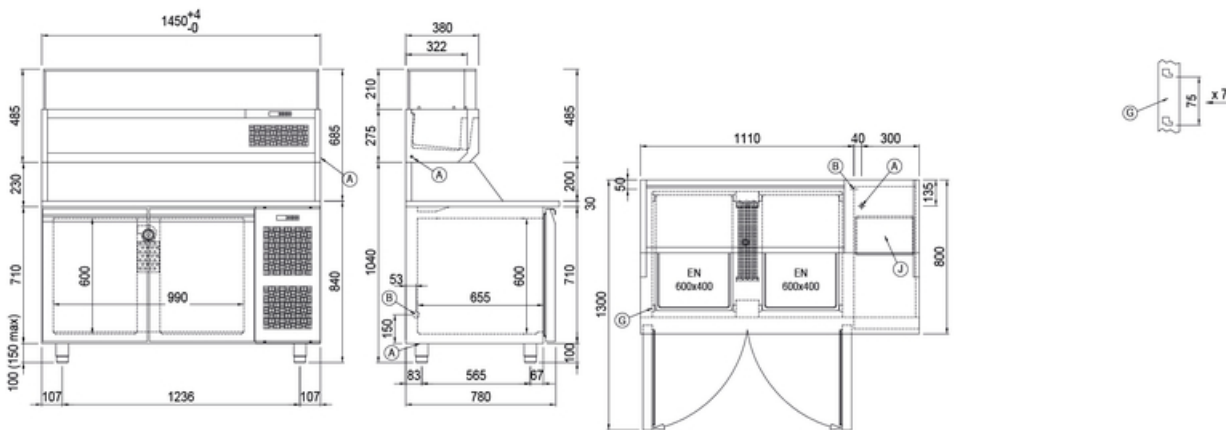

- A:** Power supply cable outlet
- G:** Racks pitch

- B:** Condensation water drain
- J:** Automatic evaporation of condensing water

In order to constantly offer the best possible products we reserve the right to make changes on technical specifications without incurring any obligation for equipment previously or subsequently sold.

Client _____ Quantity _____
Project _____ Position _____

Display case for ingredients 1450 mm



Model: VP14/6NL

Cod: V42141010001

Technical data

| | |
|----------------------------|---------------------------------|
| Gross capacity: | 51 lt |
| Temperature range: | +2°+10°C |
| Refrigerant unit: | Plug-In |
| Cooling gas: | R290 |
| Valve: | Supplied standard with solenoid |
| Dimensions: | 1450×380×485 mm |
| Packing dimensions: | 1510×450×473 mm |
| Gross weight: | 65 Kg |
| Voltage: | 220-240 V - 50 Hz |
| Total rate: | 250 W |
| Absorbed Current: | 1,15 A |
| Cooling capacity: | 406 W* |
| *: | Evap. -10°C Cond. +55°C |

Features

| | |
|-------------------------------------|--|
| Control: | Electronic, display flush with the panel |
| Insulation: | 30 mm thickness - CFC/HCFC free |
| Exterior/interior finishing: | Exterior and interior AISI 304 stainless steel. |
| Inner corners: | Rounded for easy cleaning and ensuring maximum hygiene |

COSMO - wi-fi control

Cosmo is the innovative wi-fi technology that allows to connect all Coldline appliances in the kitchen and monitor them constantly from your smartphone. Connect Display case for ingredients to a Cosmo hub (MODI, VISION or LEVTRONIC) and from the app you can check the operating conditions of each machine in real time and receive any alerts in the event of power cuts or improper personnel interventions.



Technical draw

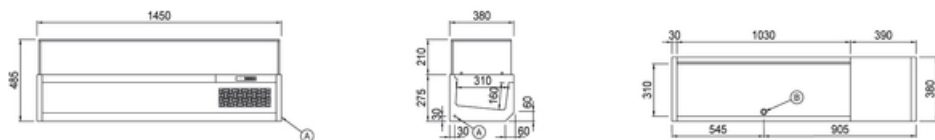

A: Power supply cable outlet

B: Condensation water drain

In order to constantly offer the best possible products we reserve the right to make changes on technical specifications without incurring any obligation for equipment previously or subsequently sold.